

quartz glass lens uv led for water disinfection

Under the same wavelength(270nm uvc led or 280nm uvc led), different power will have different radiated flux. Al reflector with Quartz Glass Lens, low light decay, this is our star products.

AL-H44GLU27-1LI2A8 20mA 270nm 1.5mW

AL-H44GLU27-1LI3A8 30mA 270nm 1.7mW

AL-H44GLU27-3LI5A8 50mA 270nm 3mW

AL-H44GLU27-5LIJA8 100mA 270nm 7mW

AL-H44GLU27-8LIKA8 150mA 270nm 10mW

AL-H44GLU28-8LIKA8 150mA 280nm 10mW

Package Dimensions

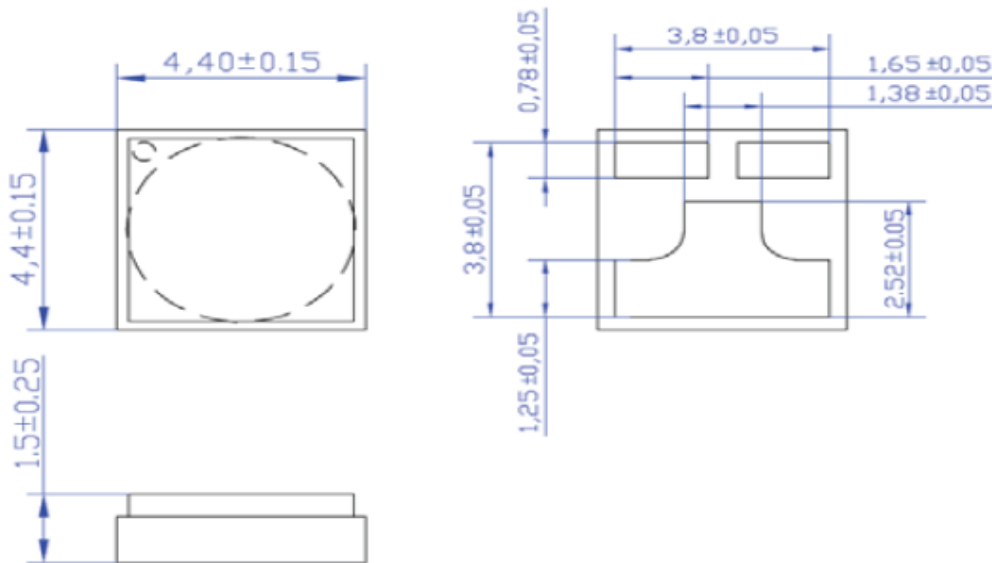

Unit: (mm)

Tolerance: ± 0.25 mm

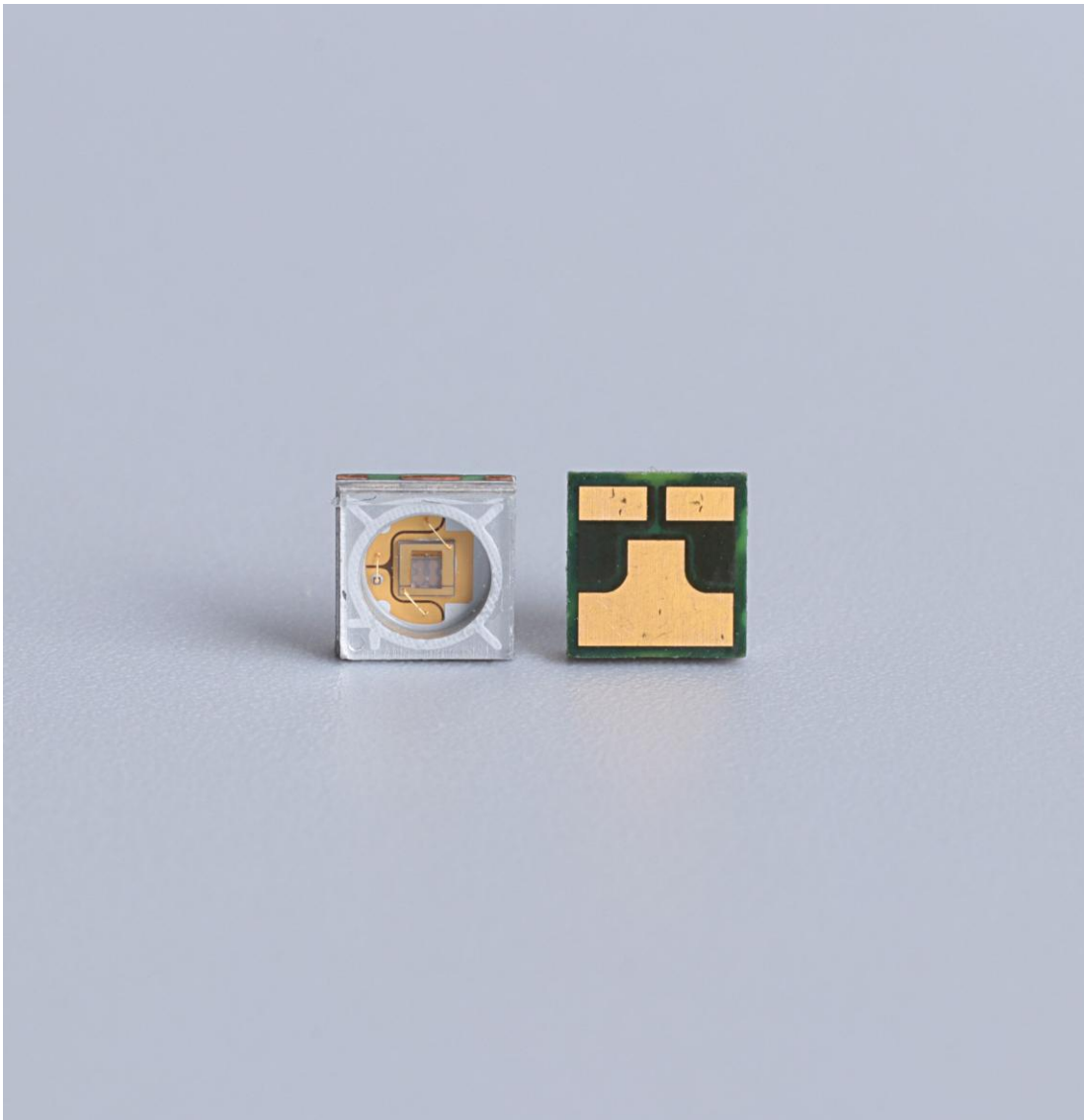

Application:

sensor for industry

sterilize water

Mosquito killing

Counterfeit Detection/Security

Dental Curing

Medical equipment

Leakage testing system

FAQ for UVC LEDs:

Q:This UVC LED lens is made of what materials?

A:Al reflector with Quartz Glass Lens, so light is stable.

Q:Do you need to know the application?

A:Yes, if convenient, we want to know the application, then we can recommend suitable power leds for you.

Q:Will you offer samples for us to test before order?

A:Yes, We also advise you to test samples first, and we glad to provide.

Q:If we find problems in the future use, will you provide technical support?

A:Yes, our best after-sales service will provide you the technical support that you want.

Welcome to receive your inquiry about our UVC leds!

WELCOME TO CONTACT US>>>>WWW.ZHIDINGLED.COM



Oversea Sales Manager

Elsa Xiao

E-mail:sales@zhidingled.com

Skype: elsa.xiao0418

Mobile: 86-13412570091

WhatsApp: 86-13412570091

Tel: 86-769-22665151

Fax:86-769-22665155